

©CAPCOM CO., LTD. 1997 ALL RIGHTS RESERVED.

MANUAL

WARNING

Asian version of this game is for the Asian countries only.

European version of this game is for the European countries only.

Oceanian version of this game is for the Oceanian countries only.

Sales, export, or operation outside these countries may be construed as copyright and trademark infringement and is strictly prohibited.

Violators are subject to severe penalties and will be prosecuted to the full extent of the law.

CAPCOM®

CAUTION

Please keep the following instructions to keep the PC board in good condition.

- Do not block the ventilation slots.
- Do not drop or bump the board.
- Do not spill any liquids on the case.
- Do not disassemble the case.

ATTENTION - When disposing of the Main and/or B-board:

The board(s) that you have purchased contains a lithium battery(s).

Please check with your local solid waste officials for details in your area for proper disposal.

CAPCOM

Disassembling the case or removing the sticker may cause the termination of your repair warranty.

No desarme la caja. Si la caja está desarmada o hay evidencia de que lo ha estado, se denegerán las reparaciones.

Ne pas démonter la boîte. Au cas où il apparaît que cette boîte a été démontée, votre demande de réparation sera refusée.

Das Gehäuse nicht öffnen. Falls das Gehäuse geöffnet wurde oder falls ersichtlich ist, daß es geöffnet wurde, wird die Reparatur verweigert.

Non smontare la scatola involucro. In caso sia stata smontata, o sia evidente che ciò è avvenuto, la riparazione sarà rifiutata

請客戶切勿私自拆卸本產品之機身／外殼。
若有拆卸或拆卸迹象之疑時，敝社概不負責維修。

케이스는 절대로 분해하지 마십시오. 만약 케이스를 분해하거나 분해한 흔적이 있는 제품에 대해서는 수리 불가합니다.

●CONTROL PANEL LAYOUT

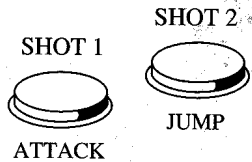
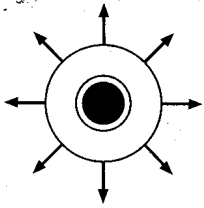

●VOLUME AND TEST SWITCHES ON BOARD

The volume can be set by the volume-up or the volume-down switch. Your setting will be saved in the memory. In case the volume setting does not work properly, press the volume-down switch for at least five seconds, then set the volume again.

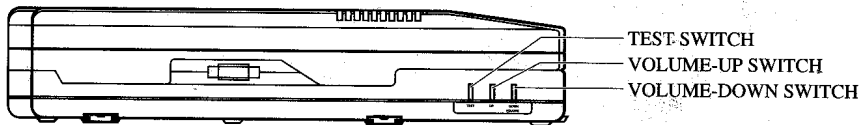

●CONNECTOR LOCATIONS

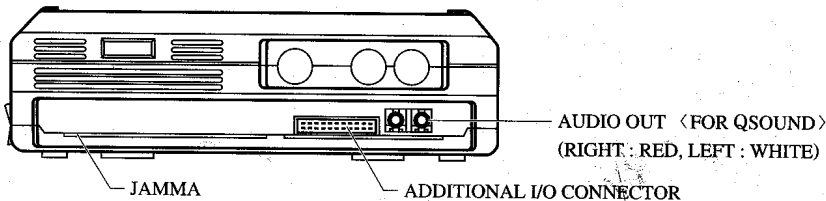

●CONNECTORS

- JAMMA:
JAMMA 56-pin connector
- ADDITIONAL CONNECTOR:
Kick Interface and Volume Control
- AUDIO OUT:
For CAPCOM QSOUND cabinet only

●JAMMA CONNECTOR

SOLDER SIDE				COMPONENT SIDE
GND	A	1		GND
GND	B	2		GND
+5V	C	3		+5V
+5V	D	4		+5V
-5V	E	5		-5V
+12V	F	6		+12V
	H	7		
N.C.	J	8		COIN COUNTER 1
(COIN LOCK OUT 2)	K	9		(COIN LOCK OUT 1)
SPEAKER(-)	L	10		SPEAKER(+)
AUDIO(GND)	M	11		AUDIO(+)
VIDEO GREEN	N	12		VIDEO RED
VIDEO SYNC	P	13		VIDEO BLUE
SERVICE SW	R	14		VIDEO GND
N.C.	S	15		TEST SW
COIN SW 2P	T	16		COIN SW 1P
START SW 2P	U	17		START SW 1P
2P UP	V	18		1P UP
2P DOWN	W	19		1P DOWN
2P LEFT	X	20		1P LEFT
2P RIGHT	Y	21		1P RIGHT
2P PUSH 1	Z	22		1P PUSH 1
2P PUSH 2	a	23		1P PUSH 2
N.C.	b	24		N.C.
N.C.	c	25		N.C.
N.C.	d	26		N.C.
GND	e	27		GND
GND	f	28		GND

※In case you change the coin chute setting on the system configuration screen, please make sure to change the additional I/O wiring referring to the following diagram.

●Additional I/O wiring for 3 or 4 player cabinet

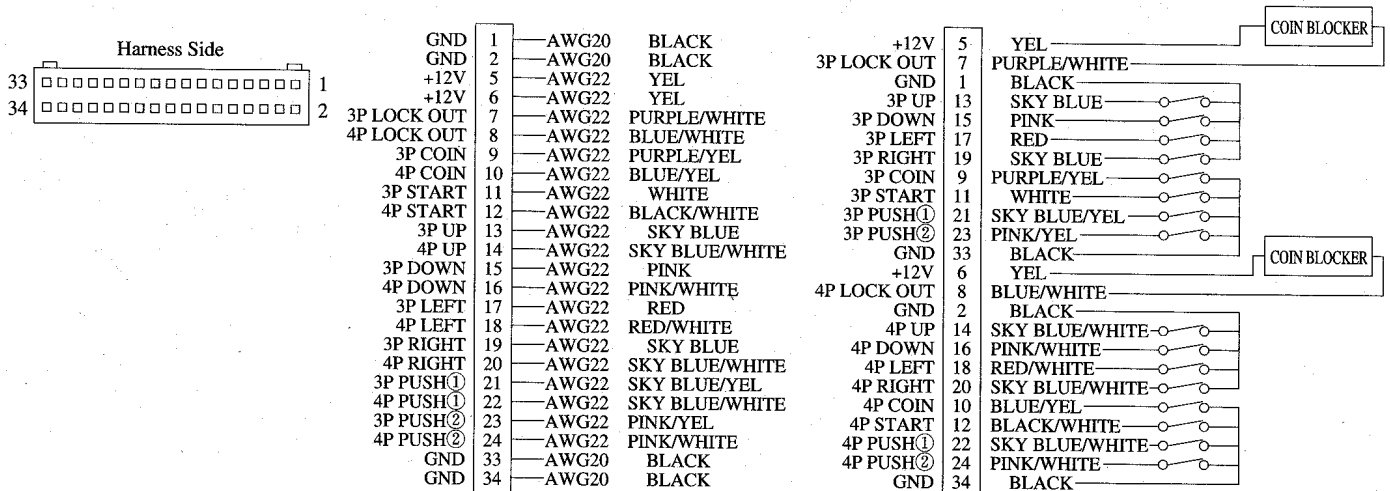

TEST MENU

The TEST MENU allows you to test the functions and the controls of the game. These items include input devices such as joysticks, buttons and coin mechs, output devices such as monitor, speakers, and meters. Through the TEST MENU you can also access the CONFIGURATION MENU, where you can change the setting of the game.

1. ACCESSING THE TEST MENU

For a CAPCOM cabinet, or a cabinet equipped with a test switch:

Turn on the main switch, then push the test switch. The screen shown below will appear.

For a cabinet without a test switch:

Push the test switch on the side of the plastic electronic casing. Refer to the VOLUME AND TEST SWITCHES ON BOARD section.

2. HOW TO SELECT AN ITEM

Use the Player 1 joystick to move the arrow to your desired item and push the Player 1 SHOT 1 button.

※To return to the TEST MENU, push the player 1 START and player 2 START buttons simultaneously.

※The screen automatically returns to TEST MENU after the MEMORY CHECK.

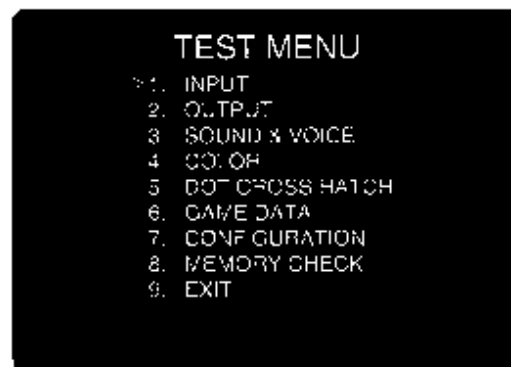

3. TEST MENU ITEM DESCRIPTIONS

1. INPUT	Used to test the input switches such as joysticks and buttons.
2. OUTPUT	Used to test the coin meter and the coin lock.
3. SOUND & VOICE	Select a code with the player 1 joystick and push the player 1 SHOT 1 button to distinguish the sound / voice, then adjust the volume.
4. COLOR	Shows color bars of red, green, blue and white. Adjust RGB and brightness to obtain the optimum color balance and solid black background.
5. DOT CROSS HATCH	Used to check the screen size, focus and distortion.
6. GAME DATA	Coin meter and the play-time information will be displayed.
7. CONFIGURATION	Used to change the settings of the game. Refer to the CONFIGURATION MENU section.
8. MEMORY CHECK	Used to test the memory. "OK" appears when each block of memory passes test. If "NG" appears, repeat the memory test. If "NG" still appears, contact your distributor.
9. EXIT	Select this item and push the player 1 SHOT 1 button to return to the game screen.

CONFIGURATION MENU

1. HOW TO SELECT AN ITEM

Use the player 1 joystick to move the arrow to your desired item and push the player 1 SHOT 1 button.

7. CONFIGURATION MENU

- >1. SYSTEM
- 2. GAME
- 3. DEFAULT
- 4. SAVE & EXIT

SELECT = 1P UP or DOWN
START = 1P SHOT 1

2. CONFIGURATION MENU ITEM DESCRIPTIONS

1. SYSTEM	Used to change the system setting.
2. GAME	Used to change the game play setting.
3. DEFAULT	Select this item and push the player 1 SHOT 1 and SHOT 2 buttons simultaneously to return to the factory setting.
4. SAVE & EXIT	Select this item and push the player 1 SHOT 1 button to save your settings and return to the TEST MENU.

※A message "SAVING NEW CONFIGURATION IN EEP ROM" appears while new settings are being saved. It takes one or two seconds to save the new settings. Do not turn off the power switch while saving is in process.

TIPS FROM CAPCOM

Possible way to increase income.

In the case you set the game to 3 or 4 player mode, we recommend to use two 2-player cabinets back to back. This way players will be able to have more space and anybody would be encouraged to join in and play together.

OPTION - For 2-player cabinet back to back, you will need to obtain a certain harness. Harness is available from Capcom.

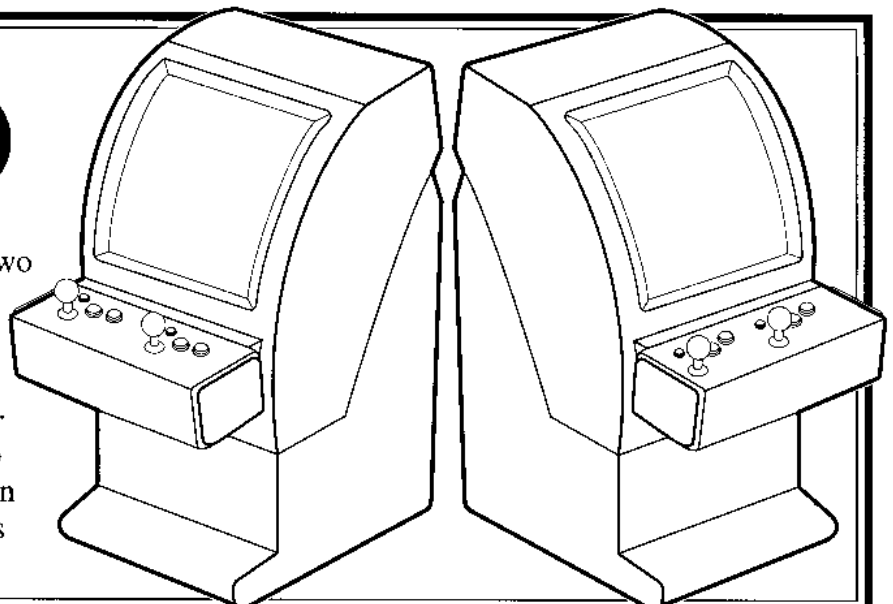

SYSTEM CONFIGURATION

1. CHANGING THE SYSTEM CONFIGURATION SETTINGS

Move the player 1 joystick up or down to highlight your desired option. Once the option is highlighted, move the joystick left or right to change the setting.

7-1. SYSTEM CONFIGURATION

- >1. COIN MODE 1 COIN 1 CREDIT
- 2. CHUTE TYPE 2 PLAYERS 2 CHUTES SINGLE
- 3. CONTINUE ON
- 4. MONITOR NORMAL
- 5. DEMO SOUND ON
- 6. SOUND MODE STEREO (Q SOUND)
- 7. LANGUAGE ENGLISH
- 8. EXIT

SELECT OPTION = 1P UP or DOWN
 MODIFY SETTING = 1P LEFT or RIGHT
 = 1P SHOT1 or SHOT2

Refer to the SYSTEM CONFIGURATION OPTIONS below.

2. SYSTEM CONFIGURATION ITEM DESCRIPTIONS

1. COIN MODE	Used to set the play fee.
2. CHUTE TYPE	Please change the coin chute settings according to the type of your cabinet. *Please make sure to change the additional I/O wiring according to your setting. COIN CHUTE SINGLE: All coin chutes will be shared. COIN CHUTE MULTI: Each coin chute will be independent.
3. CONTINUE	Used to set the continuous play.
4. MONITOR	Used to flip the screen vertically. If the screen appears upside down, change the setting.
5. DEMO SOUND	Used to turn the attract sound on or off.
6. SOUND MODE	STEREO(Q SOUND) is available with CAPCOM Q SOUND cabinets only. For other cabinets, please set to MONAURAL.
7. LANGUAGE	Used to set the screen text language.
8. EXIT	Select this item and push the player 1 SHOT 1 button to return to the CONFIGURATION MENU.

• SYSTEM CONFIGURATION OPTIONS

1. COIN MODE	1 COIN 1 CREDIT	1 COIN 2 CREDITS	1 COIN 3 CREDITS	1 COIN 4 CREDITS
	1 COIN 5 CREDITS	1 COIN 6 CREDITS	1 COIN 7 CREDITS	1 COIN 8 CREDITS
	1 COIN 9 CREDITS	2 COINS 1 CREDIT	3 COINS 1 CREDIT	4 COINS 1 CREDIT
	5 COINS 1 CREDIT	6 COINS 1 CREDIT	7 COINS 1 CREDIT	8 COINS 1 CREDIT
	9 COINS 1 CREDIT	2 COINS START 1 COIN CONTINUE	FREE PLAY	
	2 PLAYERS 1 CHUTE SINGLE	2 PLAYERS 2 CHUTES SINGLE	2 PLAYERS 2 CHUTES MULTI	4 PLAYERS 1 CHUTE SINGLE
4 PLAYERS 2 CHUTES SINGLE	4 PLAYERS 2 CHUTES MULTI	4 PLAYERS 4 CHUTES SINGLE	4 PLAYERS 4 CHUTES MULTI	
3. CONTINUE	ON		OFF	
4. MONITOR	NORMAL		FLIP	
5. DEMO SOUND	ON		OFF	
6. SOUND MODE	STEREO (Q SOUND)		MONAURAL	
7. LANGUAGE	ENGLISH	SPANISH	PORTUGUESE	

• GAME CONFIGURATION OPTIONS

1. DIFFICULTY	1	2	3	4
	EASIEST	VERY EASY	EASY	MEDIUM
2. EXTEND	5	6	7	8
	MEDIUM HARD	HARD	VERY HARD	HARDEST
3. NUMBER OF PLAYERS	NOT EXTEND	ONLY 500000	ONLY 800000	ONLY 1200000
	FIRST 500000	EVERY 800000	FIRST 1200000	FIRST 1500000
	EVERY 600000		EVERY 1000000	EVERY 1200000
	START = 1	START = 2	START = 3	START = 5
CONTINUE = 1	CONTINUE = 2	CONTINUE = 3	CONTINUE = 5	
	START = 1	START = 2	START = 3	START = 5
CONTINUE = 2	CONTINUE = 3	CONTINUE = 4	CONTINUE = 6	

※ Factory setting

※ There is no language function in Asia version.

※ Factory setting

GAME CONFIGURATION

1. CHANGING THE GAME CONFIGURATION SETTINGS

Move the player 1 joystick up or down to highlight your desired option. Once the option is highlighted, move the joystick left or right to change the setting.

7-2. GAME CONFIGURATION

>1. DIFFICULTY EASY<---4--->HARD
 2. EXTEND NOT EXTEND
 3. NUMBER OF PLAYERS =2
 CONTINUE =2
 4. EXIT

SELECT OPTION = 1P UP or DOWN
 MODIFY SETTING = 1P LEFT or RIGHT
 = 1P SHOT1 or SHOT2

Refer to the GAME CONFIGURATION OPTIONS below.

2. GAME CONFIGURATION ITEM DESCRIPTIONS

1. DIFFICULTY	Used to set the game difficulty level. The higher the number, the more difficult the game play.
2. EXTEND	Sets the point level at which player gets 1 up. 7 different settings + NOT EXTEND setting are available.
3. NUMBER OF PLAYERS	Sets the initial number of life(s).
4. EXIT	Select this item and push the player 1 SHOT 1 button to return to the CONFIGURATION MENU.

CARTRIDGE STICKERS

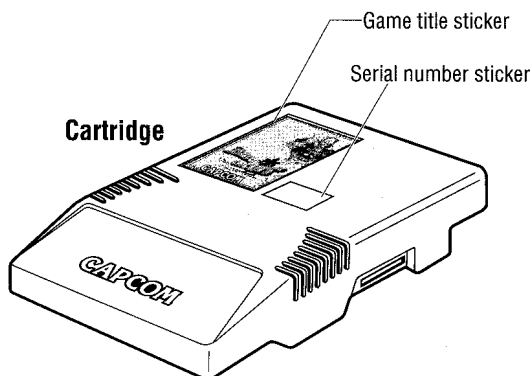

Reverse side of the cartridge

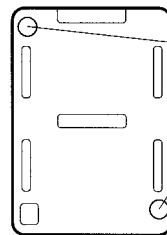

Sealing sticker
(Warning information)

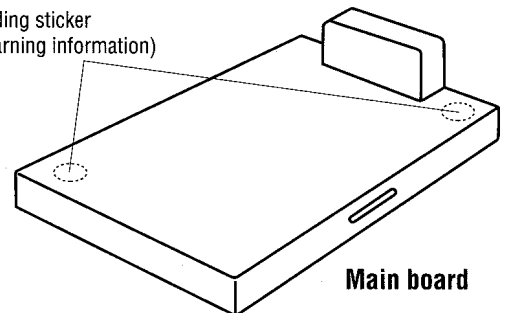

※WARNING INFORMATION

Disassembling the case or removing the sealing stickers will void your warranty

HOW TO REMOVE THE TOP "B" CARTRIDGE

The top "B" cartridge is interchangeable to a new game or upgraded to a different version.

It is very important to separate only the top cartridge from the main board. **Disassembling either case will void your warranty.**

Follow the instructions below to separate the two boards.

- Remove the 2 case clamps.
- Carefully pull the "B" cartridge off the bottom cartridge.

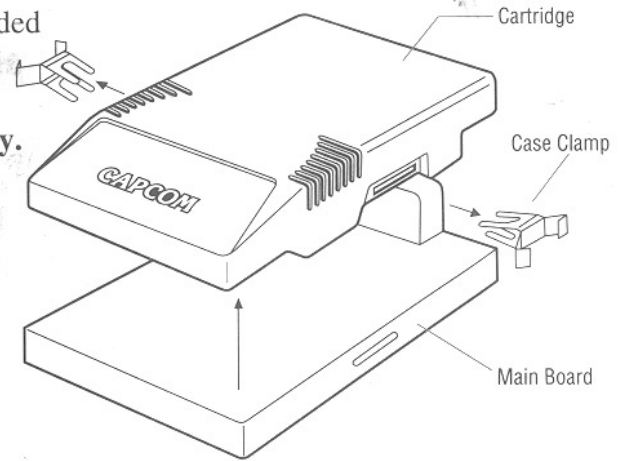

MOUNTING THE PC BOARD

1. INSTALLING THE MOUNTING BRACES

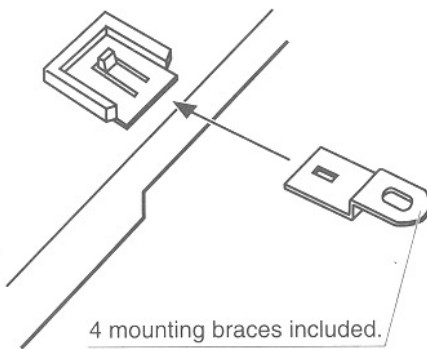

2. MOUNTING THE PCB

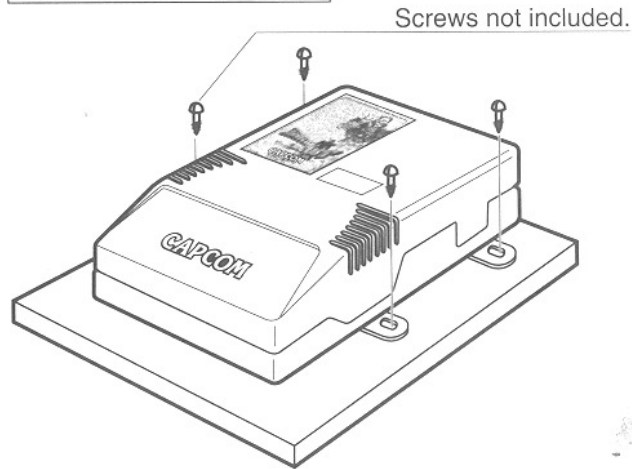

PLAY INSTRUCTION STICKERS

※THE INSTRUCTION STICKERS ARE VERY IMPORTANT FOR THE PLAYERS TO UNDERSTAND THE GAME PLAY. PLEASE PUT THEM IN A PROMINENT PLACE NEAR THE CABINET. BELOW IS AN EXAMPLE.

INSTRUCTION STICKER (A)

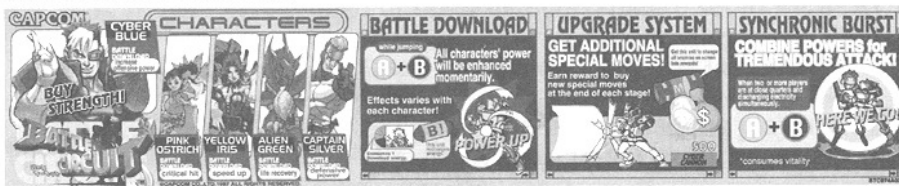

Instruction Sticker (A)

Instruction Sticker (B)

INSTRUCTION STICKER (B)

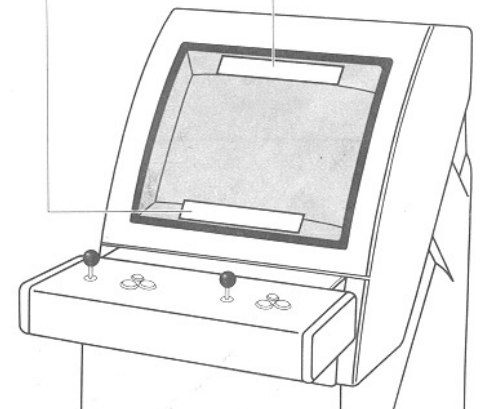

CAPCOM® CO., LTD.

No. 1-3, UCHIHIRANOMACHI 3-CHOME,
CHUO-KU, OSAKA 540, JAPAN
TEL(06)920-3635 FAX NO.(06)920-5134